

CityLine/CityVu TimberLine/TimberVu C-Series W-Series H-Series 3/8" Subsill Water Management Installation Guide

IG-076 REV. 08/23 1.2

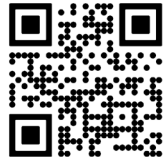

CityLine TimberLine

Scan Here for a Digital Version of the Installation Guides in English.

Quartz Luxury Windows & Doors:
www.quartzluxurywindows.com



CityVu TimberVu

Scan Here for a Digital Version of the Installation Guides in English.

Quartz Residential Windows & Doors:
www.quakerresidentialwindows.com

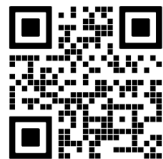

C-Series W-Series H-Series

Scan Here for a Digital Version of the Installation Guides in English.

Quaker Commercial Windows & Doors:
www.quakercommercialwindows.com



Para ver las instrucciones en Espanol, escanea aqui.

If this set of instructions does not match your installation method or the wall conditions of the job site, please check our website listed below for other options, or call Quaker Customer Service for additional information.



Quaker Window Products
504 U.S. Hwy 63 South
Freeburg, MO 65035
(800) 347-0438
www.quakerwindows.com



CityLine/CityVu TimberLine/TimberVu C-Series W-Series H-Series 3/8" Subsill Water Management Installation Guide

Read these instructions completely before starting any installation. Failure to install and maintain our product according to these instructions may void any product warranty. Please visit our website at www.quakerwindows.com or call 1-800-347-0438 for additional information.

Tools required by installer:

Safety Glasses		Utility Knife	
Drill/Driver		Caulk Gun	
Level		Tape Measure	
Hammer		Pliers	

Materials required by installer:

Foam Backer Rod		Minimally Expanding Foam	
Shims (Waterproof)		Sealant	
Fasteners		IPA Alcohol	
			

Quaker Supplied Parts:

U-Channel (Optional)

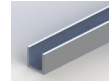

Sill Flashing



WARNING

Tools

- Follow manufacturer's instructions for safe operation of tools, and ladders/scaffolding. Always wear safety glasses. Failure to do so could result in injury, product or property damage.

Handling

- Do not store units outside, or in a hot environment. Doing so could result in product damage.
- Do not carry flat.** Doing so could result in product damage, injury, or property damage.
- Stack units as straight as possible to avoid bowing. **Do not lay flat!**

Glass

- If broken, glass can fragment causing injury. All Quaker products are available with safety glass. In many areas, local building codes require safety glass in certain locations and/or applications. Unless safety glass is ordered, Quaker windows are not provided with safety glass. Before ordering, consult your local building codes for more definitive information.

Fastening

- Metal fasteners and components could corrode when used with preservative-treated lumber. Use approved fasteners and components to fasten window or door. Failure to do so could cause a failure resulting in injury, product or property damage.
- Fastener must attach to a structural framing member with 1 1/2" minimum fastener embedment, or minimum 3 full threads with a minimum 5/16" head as products were tested with.
- Quaker does not supply anchorage/fastener calculations, and is not responsible for determining structural adequacy of the anchorage and fasteners used to install our products, or the openings into which they are installed.**
- Do not over drive screws or nails.** Doing so could result in product damage.

CAUTION**Installation**

- Always support window or door in opening until fully fastened. Failure to do so could result in the window or door falling out or causing injury, product, or property damage.
- Nailing flanges and drip caps (integral or applied) **do not** take the place of window flashing. All windows and doors must be properly flashed and sealed with material compatible sealant for protection against water and air infiltration around the entire perimeter. Failure to do so could result in product or property damage.
- **Do not** set window directly on sill plate. Place shims under the side jambs. Window or door must be properly shimmed. Failure to do so could affect operation and product performance and could result in product damage.
- Live or dead loads transferred into our product can affect functionality, damage frame joinery or cause glass failures. Dead loads such as upper levels, roof, etc. Should be constructed before window or door is installed.
- Loads shall be designed to withstand the most critical effects of load factors and load combinations as required by the building code. (Loads are including but not limited to Live, Dead, Collateral, Auxiliary, Thermally induced, Seismic, etc.)
- Maximum vertical deflection of the header under all Load combination should not exceed the Span/720 or 1/4" whichever is less.
- Windows and doors have small parts. Small parts if swallowed could pose a choking hazard to young children. Dispose of unused, loose, or easily removed small parts. Failure to do so could result in injury.
- **Do not** drill through or into window sill to install alarm wires.

Sealing

- Follow instructions of foam, sealant, and flashing manufacturers regarding safety, material application, compatibility, and periodic maintenance for continued weather resistance of their products. Failure to do so could result in product or property damage. **DO NOT** overfill between the frame and opening.
- Minimally expanding foam insulation must be compliant with AAMA 812-19.
- Quaker recommends 100% silicone (ASTM C920 compliant) neutral cure only sealant. Always clean all areas where sealant will be applied. Failure to do so could result in product or property damage.
- Flashing tape must meet ASTM-D779 performance requirements.
- Maintain a minimum of 1/4" between the window or door frame and exterior finish materials. Failure to do so could result in product or property damage.

Joining

- Do not join any window or door to any window or door not designed for joining. Joined windows and doors must be individually supported in the opening. Failure to do so could affect operation and product performance and could result in product or property damage.

Cleaning

- Acid solutions used for cleaning will damage glass, fasteners, hardware, and metal flashing. Protect these products and follow cleaning products manufacturers instructions. If acid contacts the window or door, wash all surfaces immediately with clean water.
- **Do not** use razor blades to clean glass surface. Glass damage could result.
- Clean glass using liquid glass cleaner.
- Clean frame, sash, panels, and insect screens using mild detergent and warm water with a soft cloth or brush.

IMPORTANT

- Buildings constructed prior to 1978 could contain lead paint which could be disturbed during window or door replacement. For more information on proper management of lead paint, go to: www.epa.gov/lead
- Care must be taken to properly recycle or dispose of old materials. Any recyclable materials should be separated from non-recyclable or hazardous materials. Please consult with local or state authorities regarding proper disposal of non-recyclable or hazardous materials.
- These are generic instructions intended to cover most common situations, which may not be appropriate for all installations due to building design, construction materials, or methods used and/or building or site conditions. Consult a contractor or architect for recommendations.
- Inspect all units for any damage or defects prior to installation. Contact the nearest Quaker distributor if there are any problems.

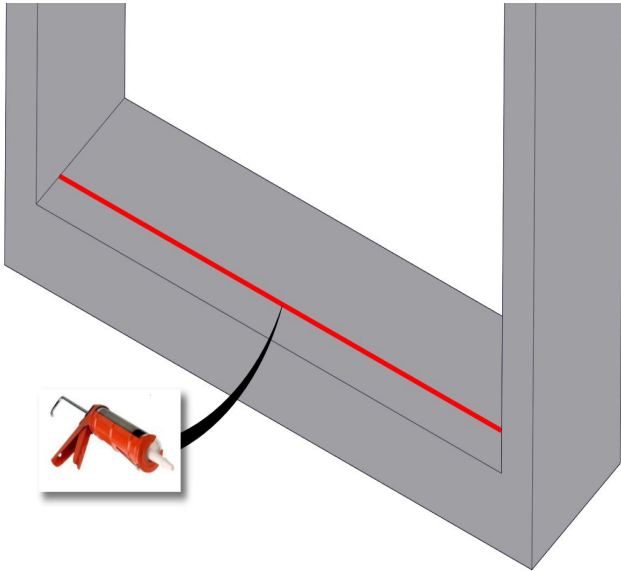
1

Apply a continuous bead of sealant that the U-Channel will sit on. Outside edge of U-Channel will be 1-9/16" from edge of opening. If sill is unlevel, shim if necessary.

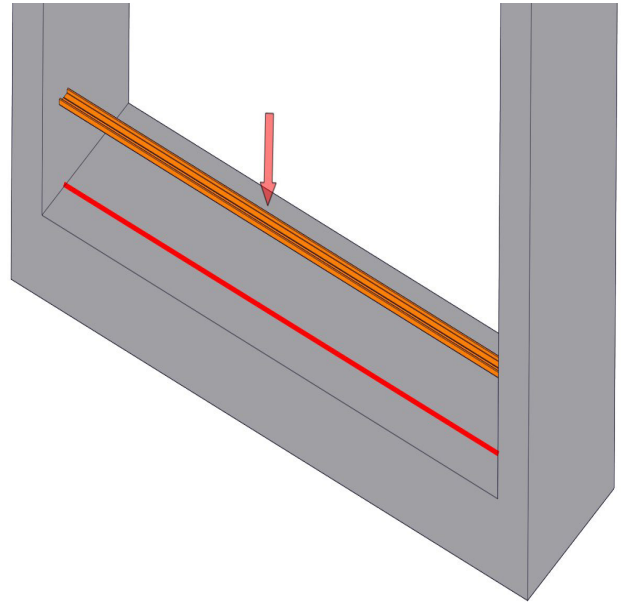
2a**Install Option #1: U-Channel**

Set U-Channel on the continuous bead of sealant.

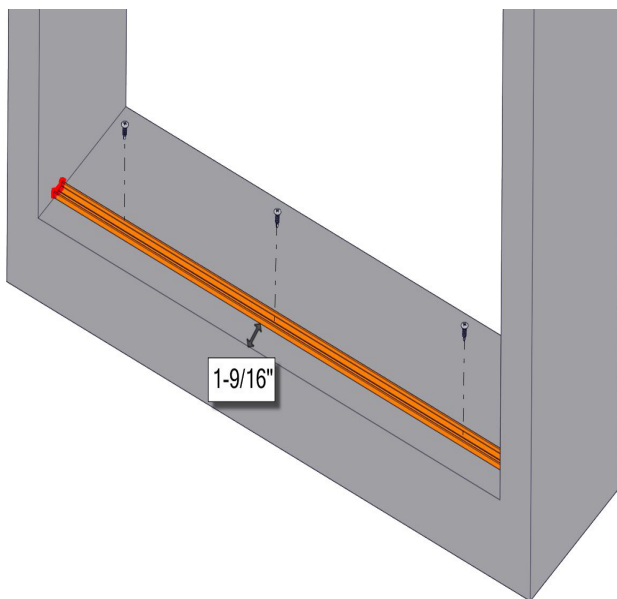
2b**Install Option #1: U-Channel**

Fasten U-Channel in place using fasteners supplied by the installer per anchorage calculations or shop drawings. Apply silicone between the U-Channel and wall at both ends. U-Channel exterior edge is 1-9/16" from the opening.

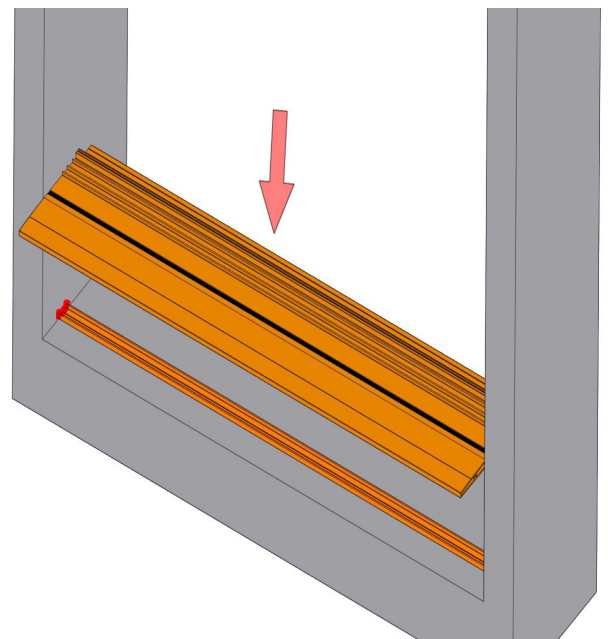
2c**Install Option #1: U-Channel**

Set sill flashing on secured U-Channel.

3 Install Option #2: Interior Anchor Leg

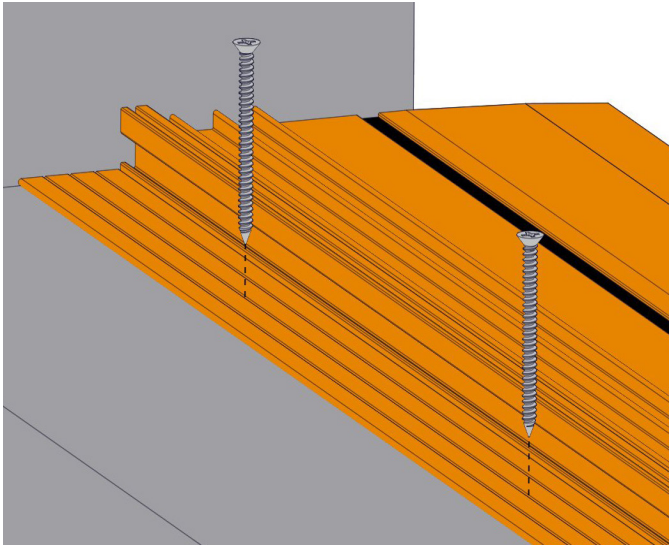

Set sill flashing on continuous bead of sealant. Screw sill flashing to anchor leg using fasteners per shop drawings or anchorage calculations. Screws are generally placed 3" off each end and every 12" in between.

4

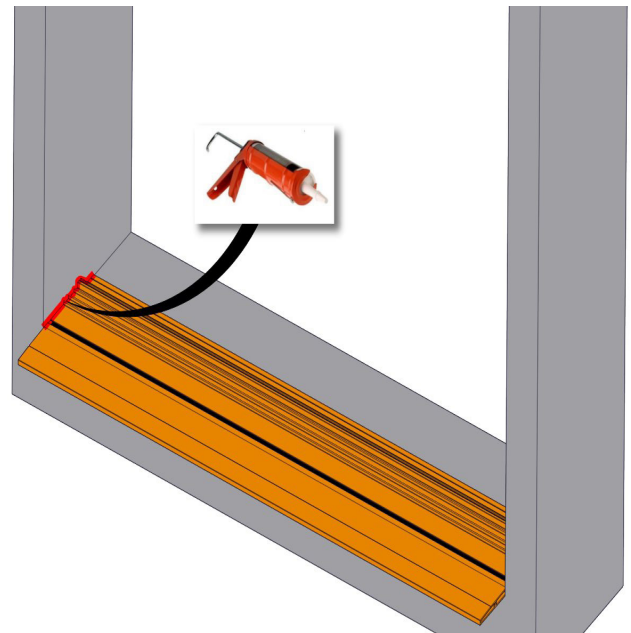

Apply a bead of sealant on each side of the sill flashing.

5

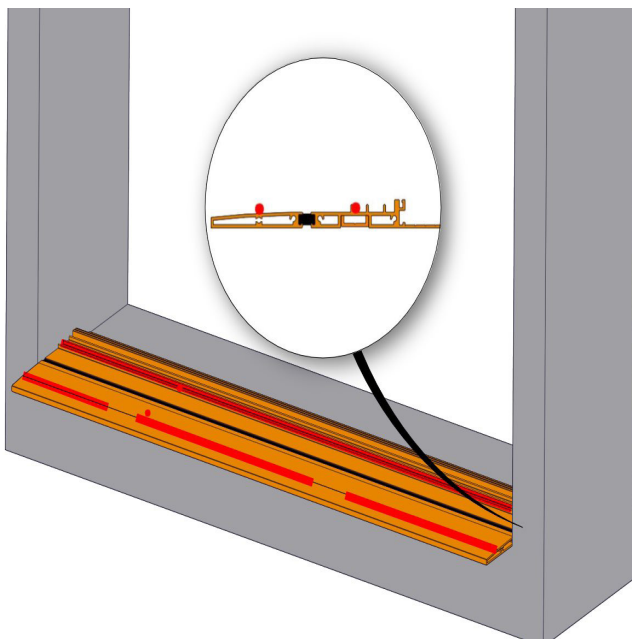

Apply a continuous bead of sealant into the track where the unit's interior edge will sit. Apply a broken bead of sealant for the exterior leg of the unit.

6

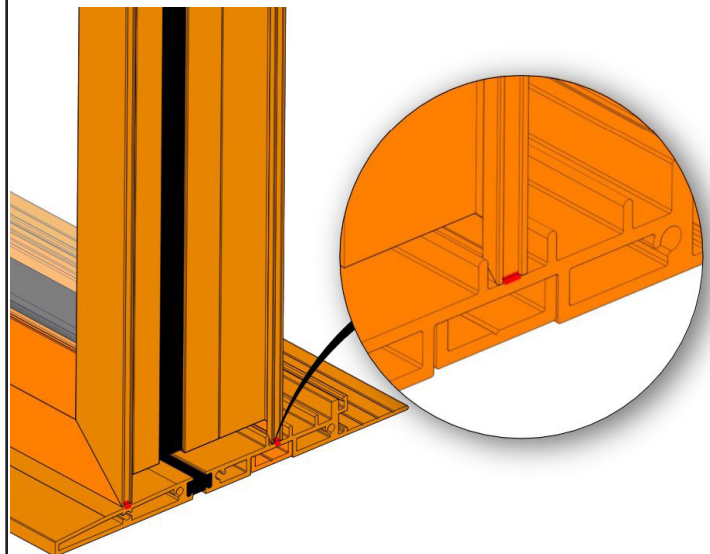

Install the unit in the continuous beads of sealant.

7

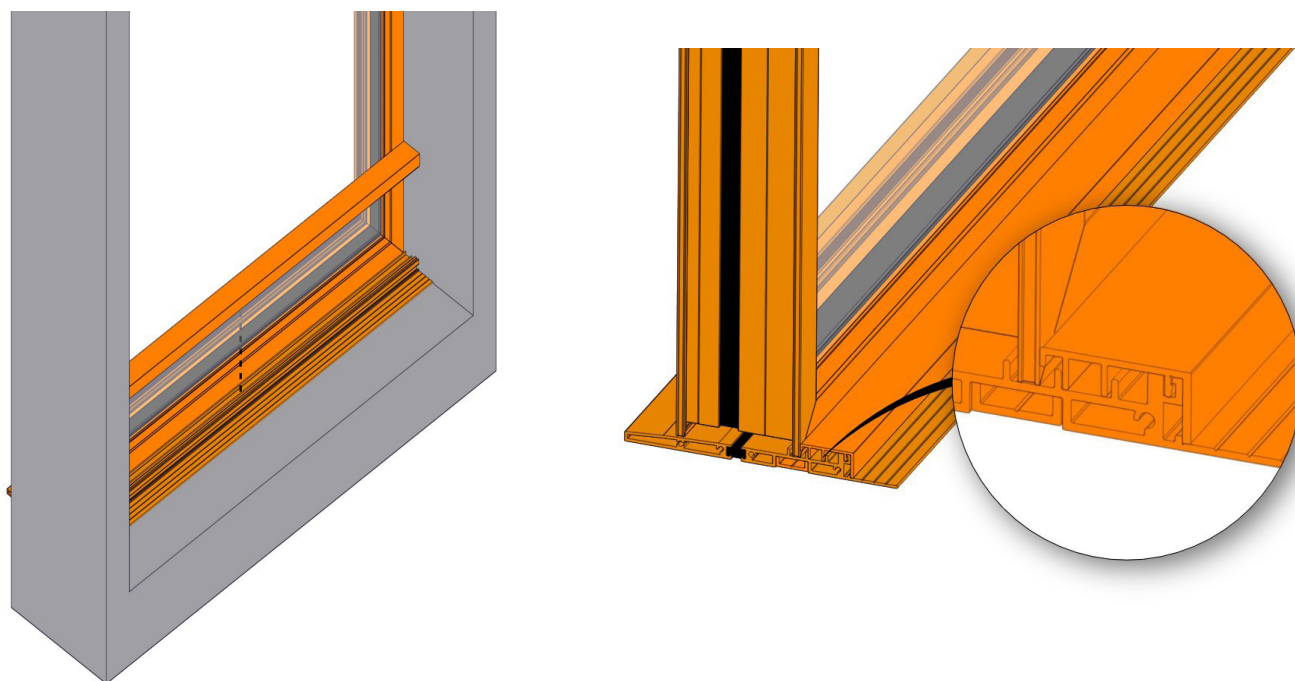

Install the flashing filler to the interior side of the unit as shown.

8

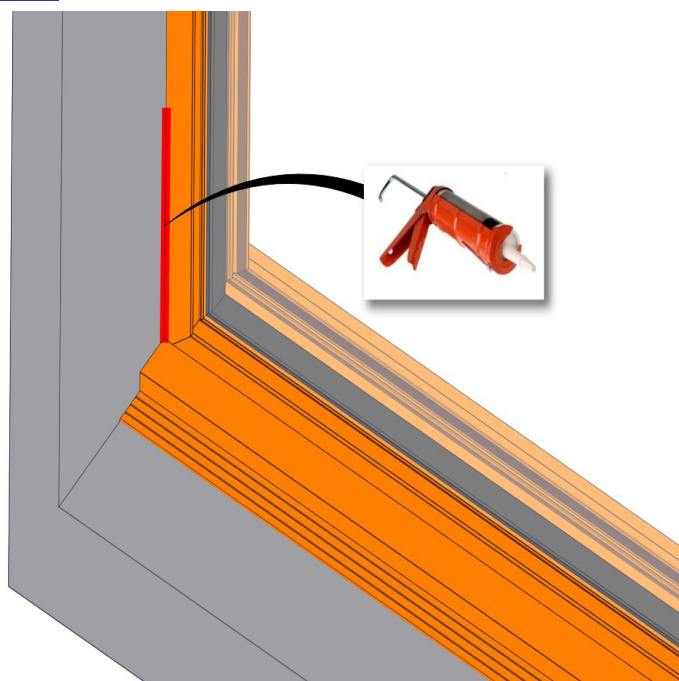

Apply a bead of sealant 6" up on each side of the window on the interior side.

Low Profile Sill Flashings by Product

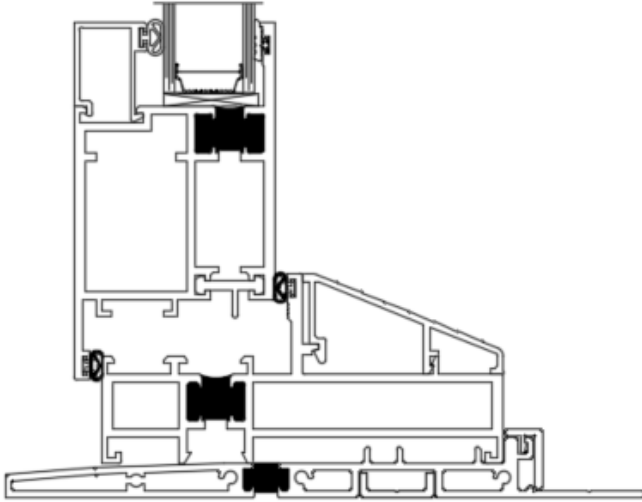

LOW PROFILE SILL FLASHING

M24494 - SILL FLASHING
M24488 - U CHANNEL
M24492 - FLASHING FILLER

M600 Terrace Door

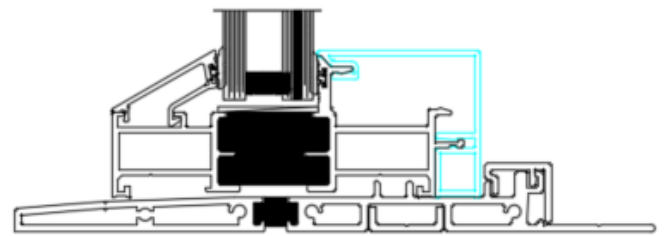

LOW PROFILE SILL FLASHING

M24494 - SILL FLASHING
M24488 - U CHANNEL
M24491 - FLASHING FILLER

C600

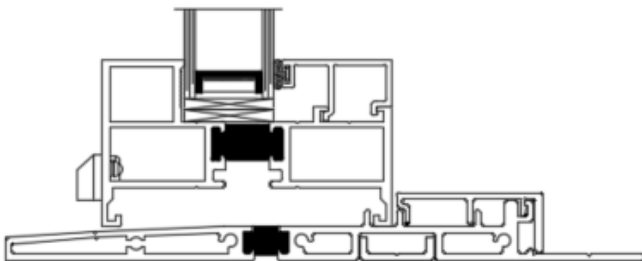

LOW PROFILE SILL FLASHING

M24494 - SILL FLASHING
M24488 - U CHANNEL
M24490 - FLASHING FILLER

M600

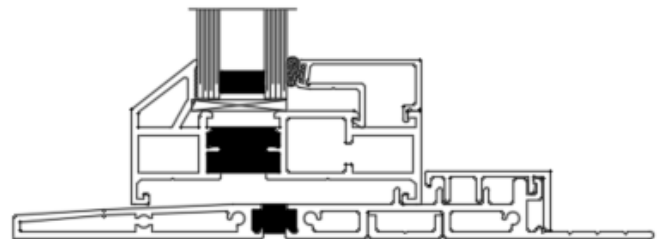

LOW PROFILE SILL FLASHING

M24493 - SILL FLASHING
M24488 - U CHANNEL
M24489 - FLASHING FILLER

H450